

1. What is included with your RL200



•

2. Find your way around the RL200



2.1 Control Panel

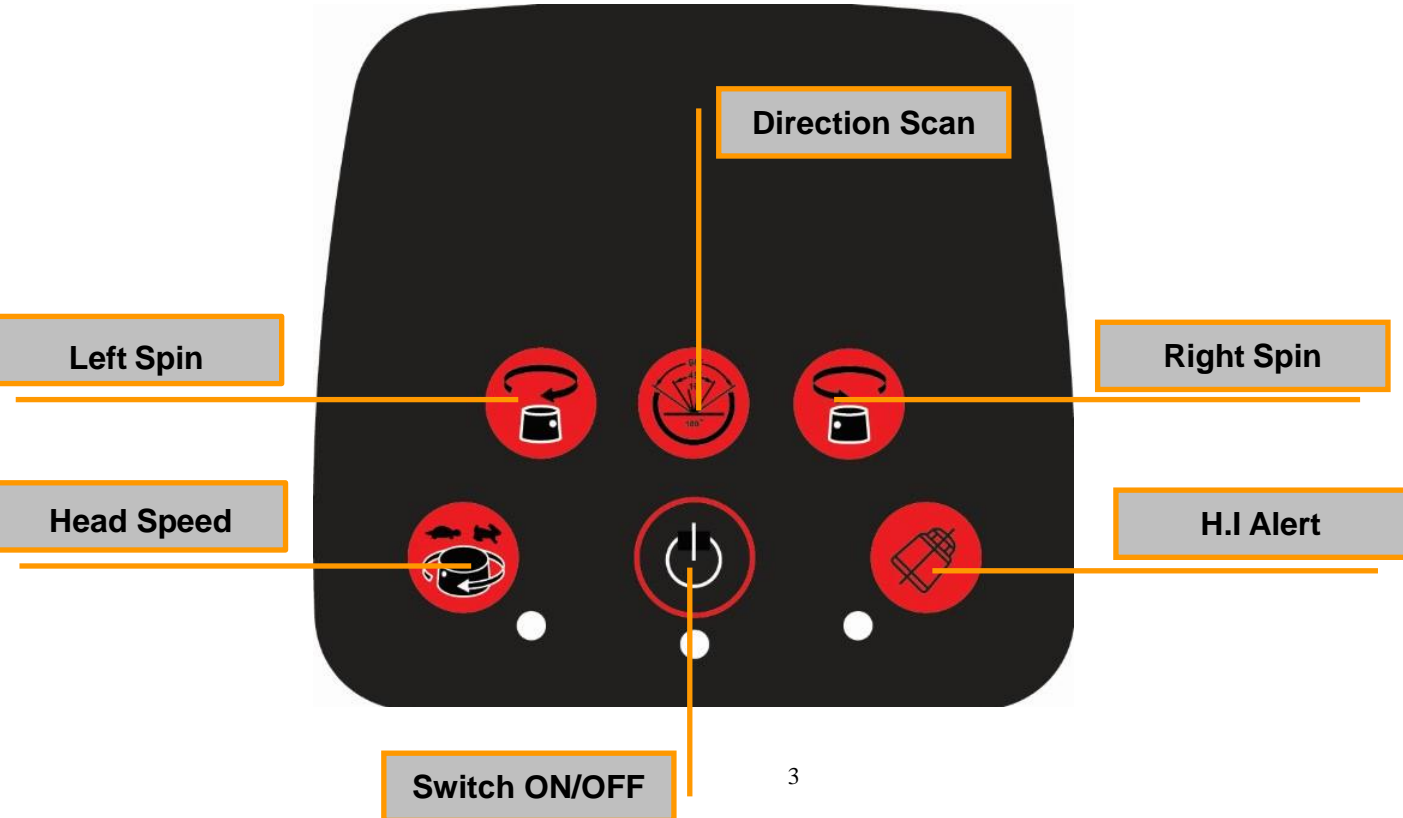

2.2 Utilities of Panel

- (1) Switch ON/OFF: Powers the laser up or down.
- (2) Power indicator: When the light is on, the instrument is on.
- (3) Head speed indicator: Indicated the current rotational speed of the unit by the speed that the LED flashes.
- (4) Head speed: Press this button to cycle through the various rotational speeds from 0 -600rpm.
- (5) Tilt/H.I alert: Enabling this mode warns the user if the laser level has been jolted.
- (6) Tilt indicator: When the light is blinking slowly, the laser is in H.I alert mode. When the light is blinking quickly, the laser level will not level as it has been jolted.
- (7) Directional scanning: Circling knob. Angle of scanning includes 5 levels: 0-10°-45° -90°-180°
- (8) Left-spinning: Used when in scan mode to rotate the laser's head counterclockwise.
- (9) Right-spinning: Used when in scan mode to rotate the laser's head clockwise.

2.3 Operations

2.3.1 Set Up (Horizontal Mode)

1. Attach the RL200 to a tripod that is as level as possible or place on a flat level surface. Make sure that the RL200 is aligned correctly on the tripod and securely tightened in position or the unit may move during use.
2. Press the Power button to turn the RL200 on and allow it to begin its leveling process. The Power indicator light will be shown indicating that the unit is on and operating.
3. Once the RL200 has completed its self-leveling process the laser will begin to rotate. Please note that the leveling time can vary based on the angle that the laser is positioned from previous use and any disturbances that the unit may be sustaining.
4. If the RL200 is outside of its leveling range the laser beam will flash continuously indicating that it is unable to level. Please do not stare directly into the laser beam.

2.3.2 Set Up (Vertical Mode)

1. Place the RL200 onto a flat level surface with the control panel facing upwards.
2. Press the Power button to turn the FRE301 on and allow it to begin its leveling process. The Power indicator light will be shown indicating that the unit is on and operating.
3. Once the RL200 has completed its self-leveling process the laser will begin to rotate. Please note that the leveling time can vary based on the angle that the laser is positioned from previous use and any disturbances that the unit may be sustaining.
4. If the RL200 is outside of its leveling range the laser beam will flash continuously indicating that it is unable to level.



2.3.3 Automatic Tilt System

To enable the tilt alarm - simply press the tilt alarm button on the control panel and then wait approximately 15 seconds. During these 15 seconds the tilt alarm indicator light will continue to flash. When the indicator light becomes constant the tilt alarm has been set.

2.3.4 Directional scanning

- (1) Press the Speed key until it is at 0 r.p.m, the laser module will stop spinning. Press the Key Directional scanning; the laser module will scan directionally. If press the key repeatedly, the angle of scanning of laser module will continuously change as follows: 0 -10- 45 -90- 180 -0 .
- (2) Press the Key Left-spinning or the Key Right-spinning to change the direction of scanning.

4. Remote

The remote control of the instrument adopts the infrared technique.

Aim the aperture of infrared ray to the instrument (as depicted below) to bring remote controlling into function (Available distance: indoor: 30M; outdoor: 20M). The keypad panel includes 5 keys; the indicator on the RC will wink to show the operating signal has been sent out once pressing any key.

Operation

1. Speed Control Button - press once to increase speed, press again to decrease speed.
2. Sleep Button - turns the laser to sleep mode.
3. Scanning Mode Button - adjusts scanning angle from 0o to 180o.
4. Rotate Left Button - rotates laser left when in scan mode.
5. Rotate Right Button - rotate laser right when in scan mode.



5. Detector

To turn the 519052 Detector on simply press the power button on the detectors control panel. The speaker will beep once and the screen will turn on indicating that the unit is operating.

The LCD screen on the 519052 Detector displays the battery level, detection mode and if the speaker is on or off.

To change between coarse and fine detection modes simply press the detection mode button on the control panel.

As the laser strikes the 519052 Detector sensor the speaker will beep and the LCD screen will display either an up or down arrow or a level line. If the screen shows either an up or down arrow move the detector up or down the staff until the level line has been located. When the level line has been located the speaker will emit a constant tone.

Detection Mode Symbols:

Coarse:5mm band

Fine:3mm band.



7. Accuracy Checking

Follow these instructions for checking axis accuracy.

7.1 Horizontal-surface Checking

1. Place the instrument at the point of 50m in front of wall (or set a scale plate at the point of 50m away from the instrument), and then adjust the level of the base approximately to aim the X1 to the wall (or scale plate), as depicted below:

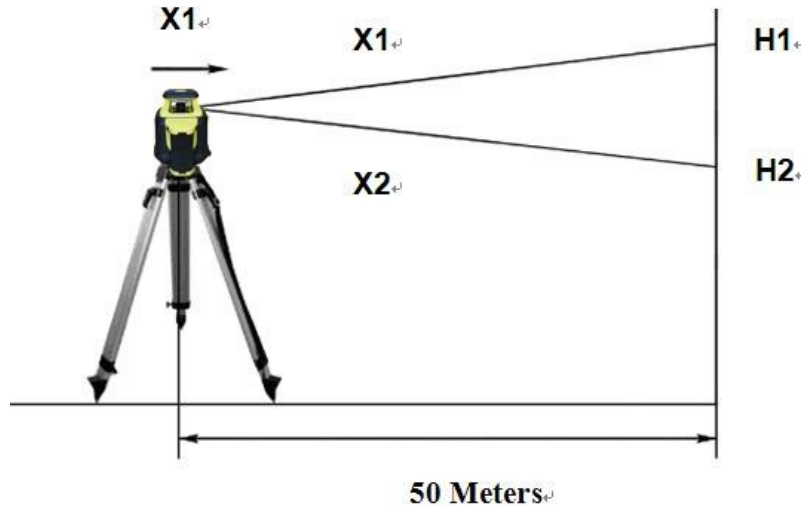

2. Allow the unit to level and begin rotating. Mark the beam position on the wall or scale plate as H1.
3. Loosen the screw of the tripod, and then turn the laser 180°. Allow the unit to level and rotate, mark the beam position on the wall or scale plate as H2.

The difference between the value of H1 and H2 should be less than 10 mm.

4. Repeat the same process to check your Y-axis beam. Again, the difference between the values of the two measurements should be less than 10 mm.
5. If the difference in either axis is more than 8mm, the laser should be sent to your authorized dealer for service/calibration.

7.2 Horizontal-line checking.

First lay down the instrument:

-Mount the instrument on tripod between A wall and B wall. Tripod near Wall A. Distance should follow the instructions on illustration. Switch the instrument on.

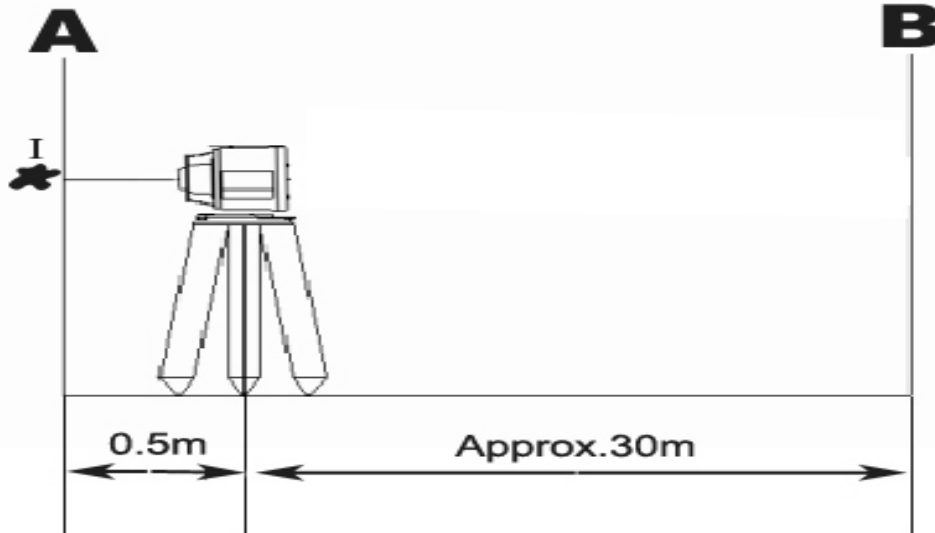

-After leveling, direct the laser beam onto the close wall A. Mark the centre point of the laser beam on the wall (Point I)

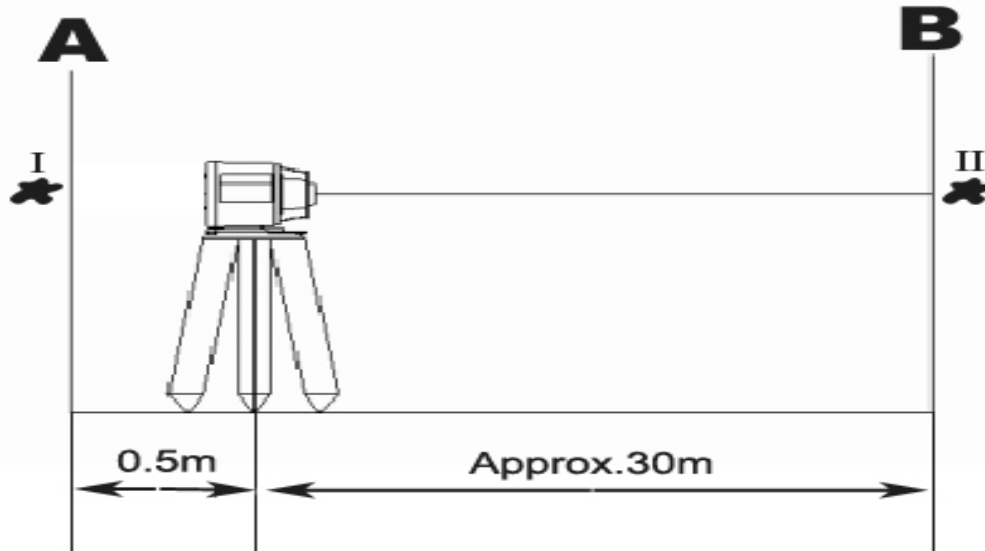

-Turn the instrument horizontally by 180° .(without changing the height).after leveling, direct the laser beam onto Wall B. Mark the centre point of the laser beam on the opposite wall B(Point II)

-Without turning the instrument. Position it close to wall B by moving the tripod. Switch on the instrument and let it leveling.

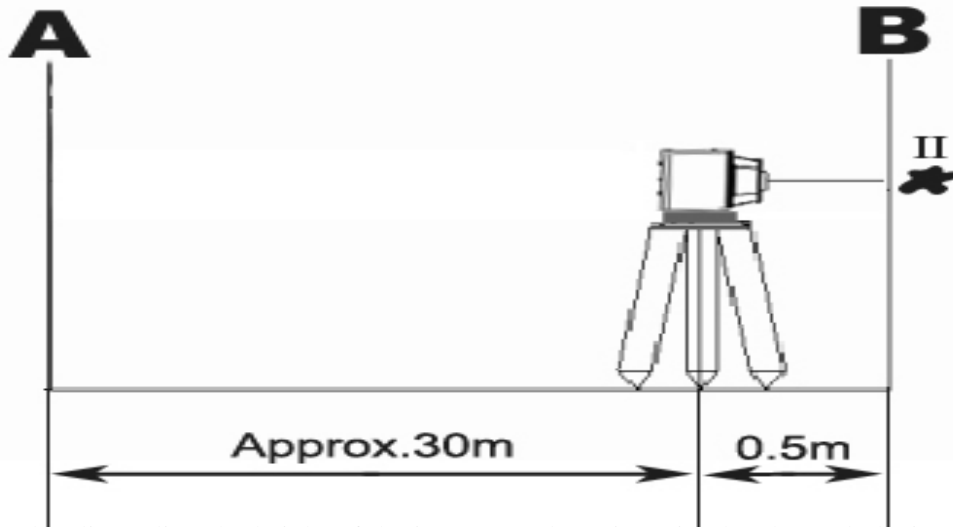

-After leveling, align the height of the instrument by using tripod or by underlaying, if necessary. In such a manner that

the center point of the laser beam is projected exactly located the previously marked point II on wall B.

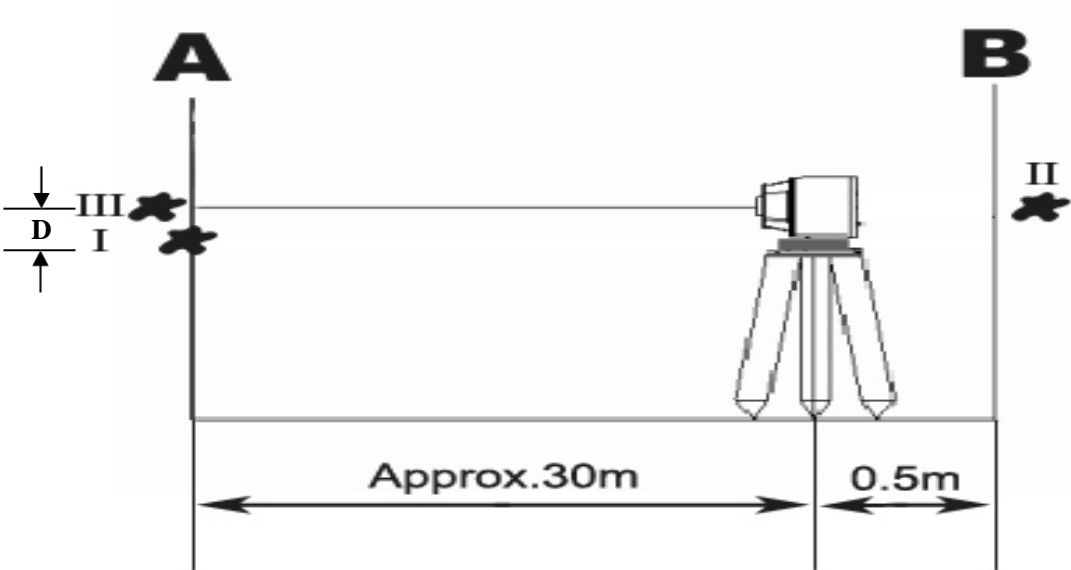

-Rotate the instrument by 180° without changing the height. Allow it to level in and mark the center point of the laser beam on wall A (point III). Tare care that point III is as vertical as possible above or below point I.

-The difference D of both marked points I and III on wall A amounts to the actual deviation of the plumb up beam

D-value should be less than 4mm.

8. Specifications

Accuracy:	20 arc seconds(+/-1mm/10m)
Self leveling range:	±5°
Operation range(With detector)	Indoors 25m Outdoor with detector up to 150m+radius 300m+ diameter
Four head speeds:	600,300 R. P. M.
Four scan widths:	10°; 45°; 90°; 180°
Bright, visible beam:	Wavelength 635nm: Class II
IR Remote control:	Available distance:20 m
Operation temperature:	-20°C ~ +50°C (-4°F~+122°F)
Power supply:	DC 4. 8-6V (4xsub-C NI-MH battery)
Continuance working time:	Approx. 50hours
Waterproof and dustproof:	IP 64
Weight:	2.0kg